

To accompany 7001C, 7080C, 7056C, 7058C, 7954C



CYCLE RACKS

Congratulations on purchasing Ezi-Grip II to carry your valued bicycles. We are sure you will get many years of enjoyable use from your Ezi-Grip II. These racks are manufactured from high-grade materials and have undergone rigorous testing making them one of the best available on the market. Testing included a one million-cycle load test to ensure the rack can perform in excess of the desired loads and lifecycle expectations.

!! ASSEMBLE THE RISER TUBE BEFORE THE HANGER TUBE !!

NZ Models: 7900C, 7906C, 7910C, 7957C, 7958C, 7959C, 7978C, 7976C, 7974C

ASSEMBLY FOR; STANDARD, 60MM OFFSET AND 4WD OFFSET RISER TUBES

- 1) Remove the grub screws and 8mm Allen key from the plastic bag.
- 2) **Note:** 2 and 3 bike racks have one grub screw and the 4 bike racks and the 4WD offset racks have two grub screws.
- 3) Dab a small amount of grease on the beginning of the thread/s, this will aid tightening against the towball and lubricate the threads.
- 4) Insert grub screws into the round nut/s at the base of the riser tube.
- 5) Place the riser tube onto the towball and tighten grub screws. It is important to ensure the grub screws are tightly fastened onto the ball. Lightly greasing the threads from time-to-time, between using your rack, will make this easier.
NOTE: This tube must be vertical at all times.
- 6) Rock the rack while pushing on the Allen key with your foot to ensure it is seated correctly. Taking care not to bend the Allen key.

YOU ARE NOW READY TO INSTALL THE HANGER TUBE AND CLAMPS TO THE RISER TUBE. REFER TO THE SEPARATE INSTRUCTIONS PROVIDED WITH THE HANGER TUBE ASSEMBLY

!!! IMPORTANT SAFETY INFORMATION !!!

- **MAXIMUM TONGUE LOAD 75kg**

This tube must be vertical at all times. A flexing, bent towbar or loose rack could cause this tube to bend. Use trunk strap Pt No: 7149 if your towbar flexes. The towbar should not flex more than 10mm at its most rearward point. Remember to rock the riser tube while firmly tightening the Allen screw/s. Periodically check tightness of rack

- **FOUR BIKE RISERS**

Four bike racks are designed for towbars with 20mm thick tongues. If your towbar tongue is not 20mm, it is strongly recommended that you do not use a 4-bike rack. Rather use a 2 or 3 bike rack or upgrade your towbar.

WARNING: 4 Bike 'Ezi-Grip' Bike Racks should only be used on towbars manufactured with 20mm thick tongue material. Using a 4 Bike Rack on a light duty towbar may cause bending of the towbar. We recommend using your rack on Best Bars Ltd towbars and trunk strap Part No: 7149 on all Ezi Grip racks

To accompany 7001C, 7080C, 7056C, 7058C, 7954C



- **STANDARD / OFFSET and 4WD OFFSET RISER TUBES**

These EZI-GRIP bike racks are designed for use on typical NZ style flat tongue towbars. This allows the bottom rim of the Bike Rack to sit firmly on a flat surface providing the necessary strength.

DO NOT FIT TO EUROPEAN STYLE "GOOSE NECK" TOWBARS.

If you have a European style towbar either replace it with a NZ style or purchase a European Style Ezigrip II, with a mounting system capable of fitting your European towbar.

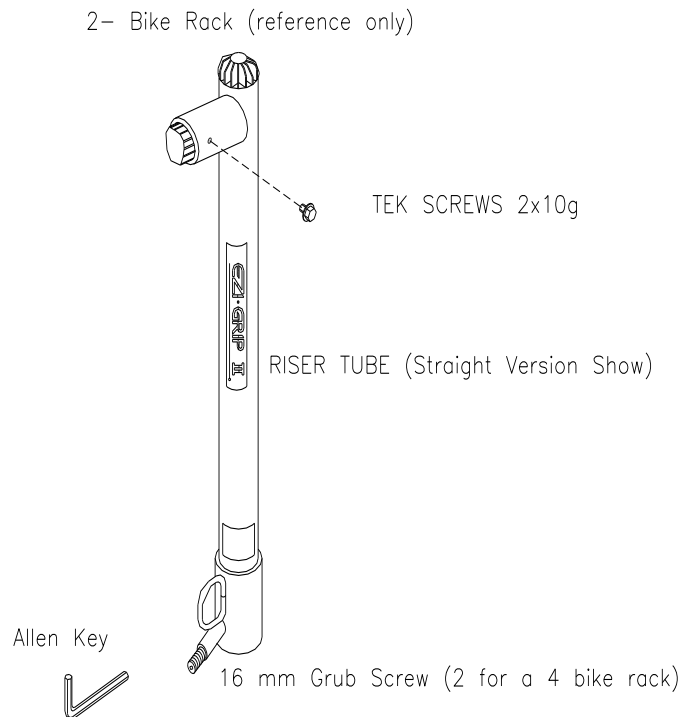

WARNING: 4 Bike 'Ezi-Grip' Bike Racks should only be used on towbars manufactured with 20mm thick tongue material. Using a 4 Bike Rack on a light duty towbar may cause bending of the towbar. We recommend using your rack on Best Bars Ltd towbars and trunk strap Part No: 7149 on all Ezi Grip racks